

Worldwide Pollution Control Association

WPCA-Southern Company
Wastewater Treatment
Seminar

April 16 & 17, 2013

All presentations posted on this website are copyrighted by the Worldwide Pollution Control Association (WPCA). Any unauthorized downloading, attempts to modify or to incorporate into other presentations, link to other websites, or to obtain copies for any other purposes than the training of attendees to WPCA Conferences is expressly prohibited, unless approved in writing by the WPCA or the original presenter. The WPCA does not assume any liability for the accuracy or contents of any materials contained in this library which were presented and/or created by persons who were not employees of the WPCA.



Visit our website at www.wpca.info





Wastewater Characteristics

16 April 2013

**Shannon R. Brown,
AQCS Engineer**

Overview

Wastewater in a Power Plant

Wastewater Treatment (WWT) Options

Characterizing Wastewater

WFGD Blowdown

System Implications & Tuning

pH & Oxidizer Content

Selenium

Mercury

Conclusion





Wastewater in a Power Plant

Systems Feeding to WWT

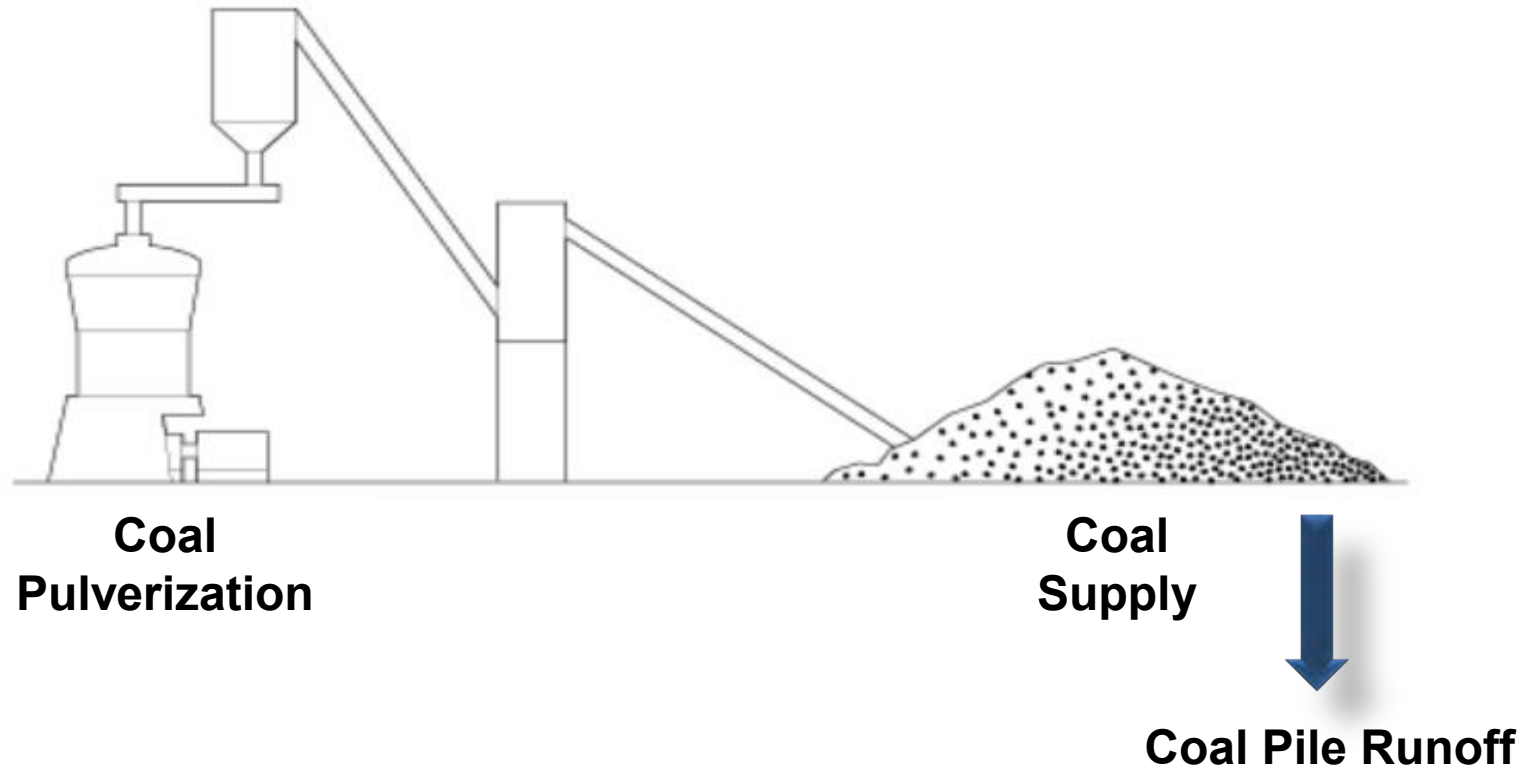

Systems Feeding to WWT

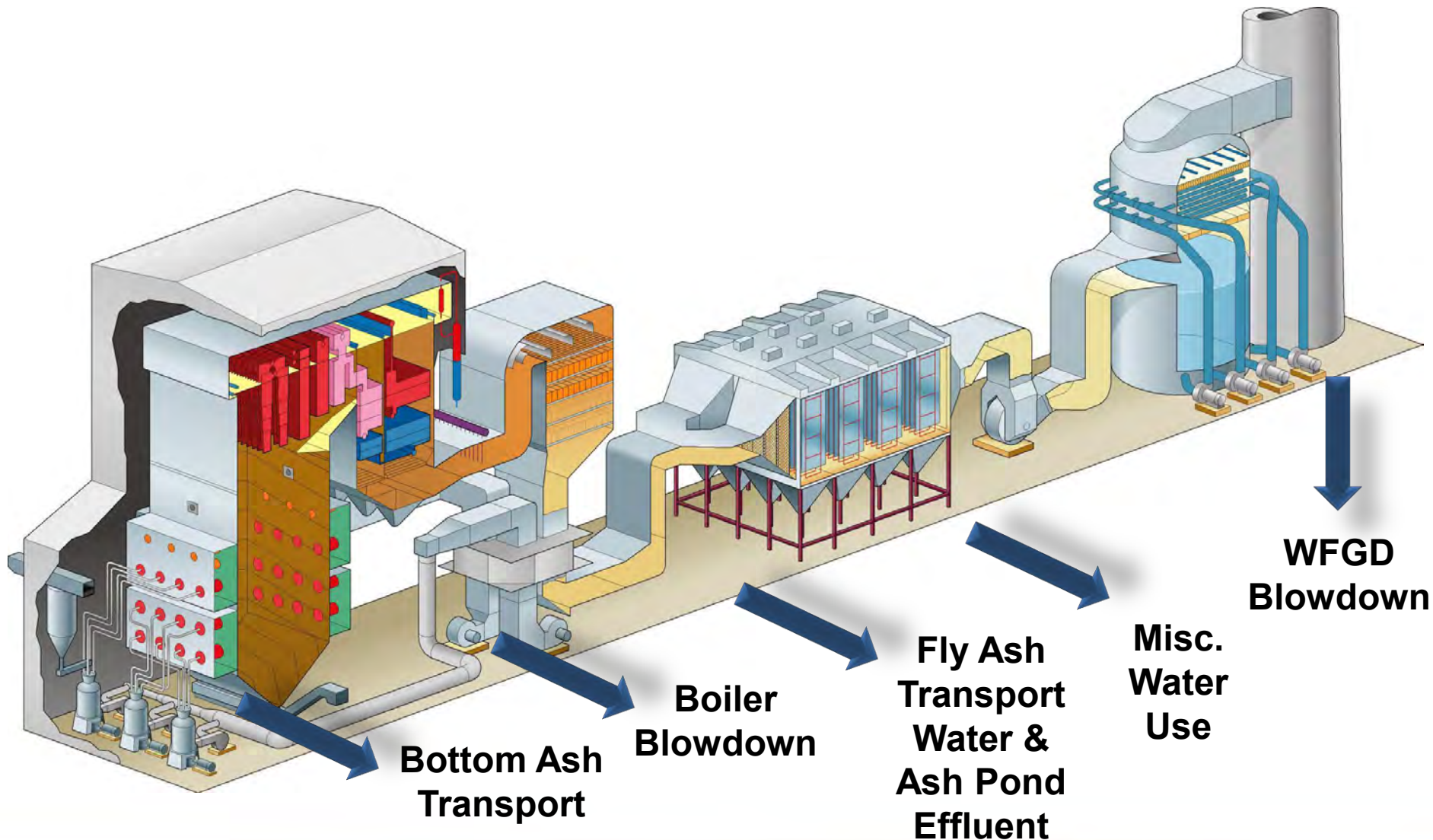

Systems Feeding to WWT

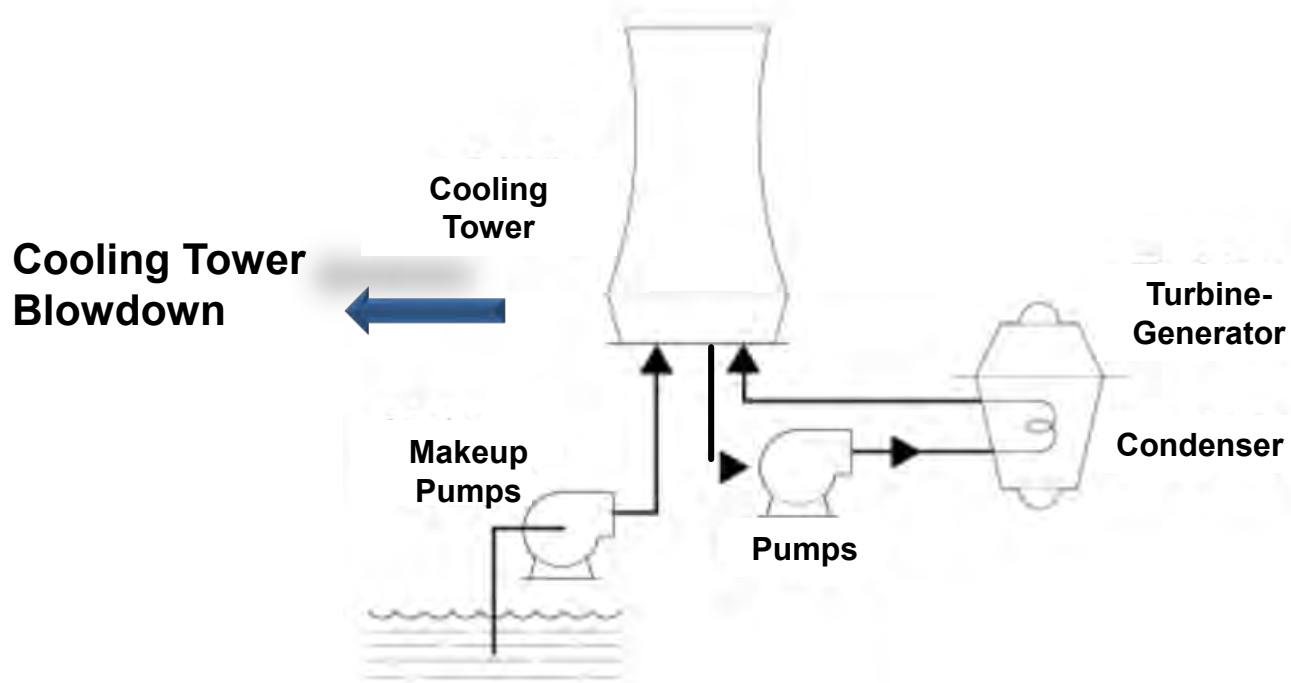

Nominal Flowrates and Bulk Properties of Wastewater Streams in a Power Plant*

Water Source	Normalized Flow Rate (gpd/MW)	TSS (mg/L)	TDS (mg/L)
WFGD Blowdown	300	10,000	30,000
Boiler Blowdown	200	5	50
Cooling Tower Blowdown	3,600	20	2,000
Ash Pond Effluent	5,000	10	1,000

*As reported by the EPA in 2009 report, DOE/NETL in 2010 report



Wastewater Treatment (WWT) Options

Technologies for Treatment of WFGD Effluent*

Settling Ponds

- Mostly to reduce suspended solids

Chemical Precipitation

- Targets mercury and arsenic removal

Biological Treatment

- Targets Selenium
- Also removes nitrates & sulfates

Operating Practices toward ZLD

Other

- Vapor-Compression Evaporation
- Clarifiers
- Constructed Wetlands
- Commingling with other wastewater
- Ash solidification

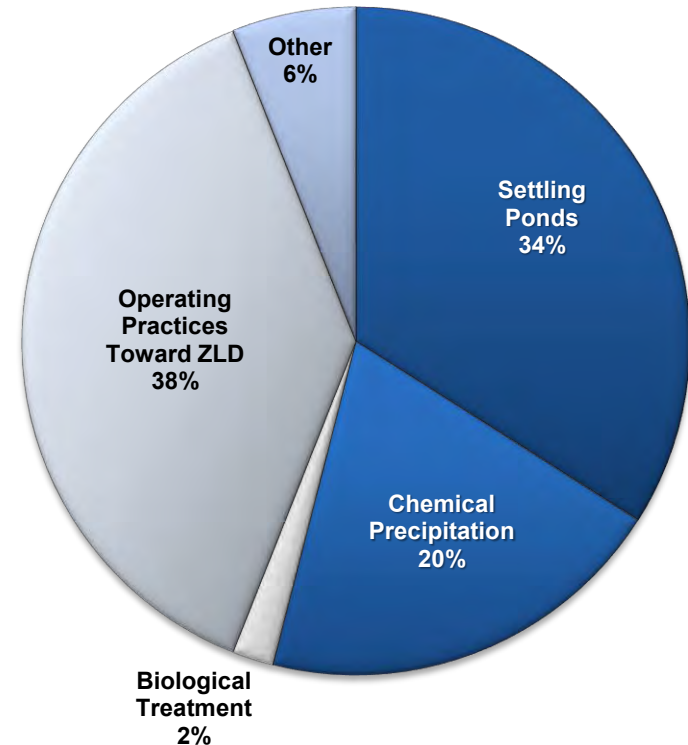

*As reported by the EPA in October 2009 report

Potential Mitigation Strategies

Pre-Treatment

- Chemical precipitation (CP) system
- Used for gypsum de-saturation & heavy metals removal
- Complete removal of Ca & Mg (by soda ash softening) desirable but expensive

Brine Concentration

- Falling film evaporator (FFE) with mechanical vapor compression (MVC)
- Reduces the water content of the wastewater by ~90%

Forced Circulation Crystallization (FCC)

- Creates crystals by further evaporating water to concentrate the stream to a value above the solubility limits of the dissolved solids
- Crystals are separated using a dewatering device such as filter press
- Generally uses either steam or MVC as the energy source

Spray Dryer Evaporation Process Flow Diagram

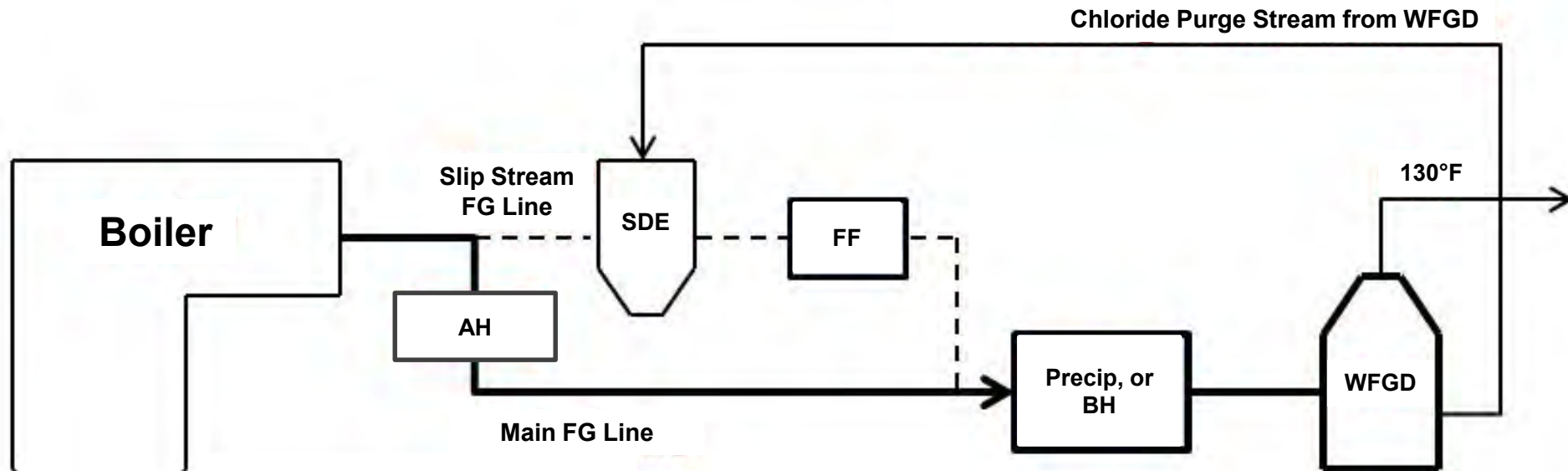

SDE: Spray Dry Evaporator
FF: Fabric Filter
FG: Flue Gas
AH: Air Heater



Characterizing Wastewater

Characterizing Wastewater: Online Process Measurements

- **Online process measurement afford the means to trend, predict and control process chemistry**
- **Recommended:**
 - **Flowrate, density, pH and ORP**
 - **Ideally, measure pH and ORP at process effluent & WWT influent points**
 - **As many WFGD systems are kinetically controlled, reactions may continue downstream of the effluent point.**

Why is ORP important?

- **ORP control the oxidation of slurry constituents**
 - Knowledge of slurry ORP, in combination with pH and chloride level, can be used to predict WFGD chemistry
 - ***Think of ORP as a threshold value. Comparing the ORP to the electronegativity and other known parameters, one can make estimations of the thermodynamically preferred and most likely state for each slurry constituent***
- **Oxidation state often controls solubility & phase partitioning of many species**

Characterizing Wastewater: Grab Sample Analysis

- **Grab samples are needed for advanced chemical analysis**
- **Commonly measure:**
 - TSS, TDS, pH, ORP, chloride content
- **Total, Speciated Anions**
 - Ion-Chromatography (IC)
- **Full Metal Scan of Speciated Metals (Cations)**
 - Inductively Coupled Plasma (ICP) Spectroscopy
- **Specific Testing for Current Regulated Metals**
 - Speciated Hg and Speciated Se



WFGD Blowdown

WFGD Effluent Composition

Nominal WFGD Effluent Stream Composition	
Species	mg/L
Boron	300
Calcium	5,000
Magnesium	2,000
Sodium	1,000
Chloride	11,000
Sulfate	5,000
TDS	25,000

Typical WFGD Blowdown Streams Pose Challenges:

- High in Halogens
- High TDS
- Selenite (IV)/Selenate (VI)
- Mercury
- Boron

Significant variation exists with WFGD absorber slurry samples

- TDS std. dev. of 15,000 mg/L

*As reported by the EPA in October 2009 report

What is ORP?

- **Oxidation Reduction Potential (ORP)**
 - **A single voltage measurement against a reference electrode**
 - Measurement technique similar to pH
 - Can be monitored on-line
 - **The strength of oxidizers and reducers in a solution in relation to their respective concentration**
 - **The more positive the voltage, the more strongly a solution would oxidize (attract electrons from) other sources**
 - Oxidizers accept electrons, reducers lose electrons.
 - **ORP can be negative**
 - Can lead to reduction of mercury to elemental state and reemission

The Relationship Between ORP and Strong Oxidizer Concentration

Total Oxidizer Titration Results

Unit	ORP Profile	Oxidizer (ppm)
1	High ORP	1680
2	High ORP	1592
3	High ORP	1574
4	High ORP	1571
5	Low ORP	227
6	Low ORP	169
7	Low ORP	50
8	Low ORP	29
9	Low ORP	27
10	Low ORP	19
11	Low ORP	10
12	Low ORP	<2

Strong Oxidizer Formation

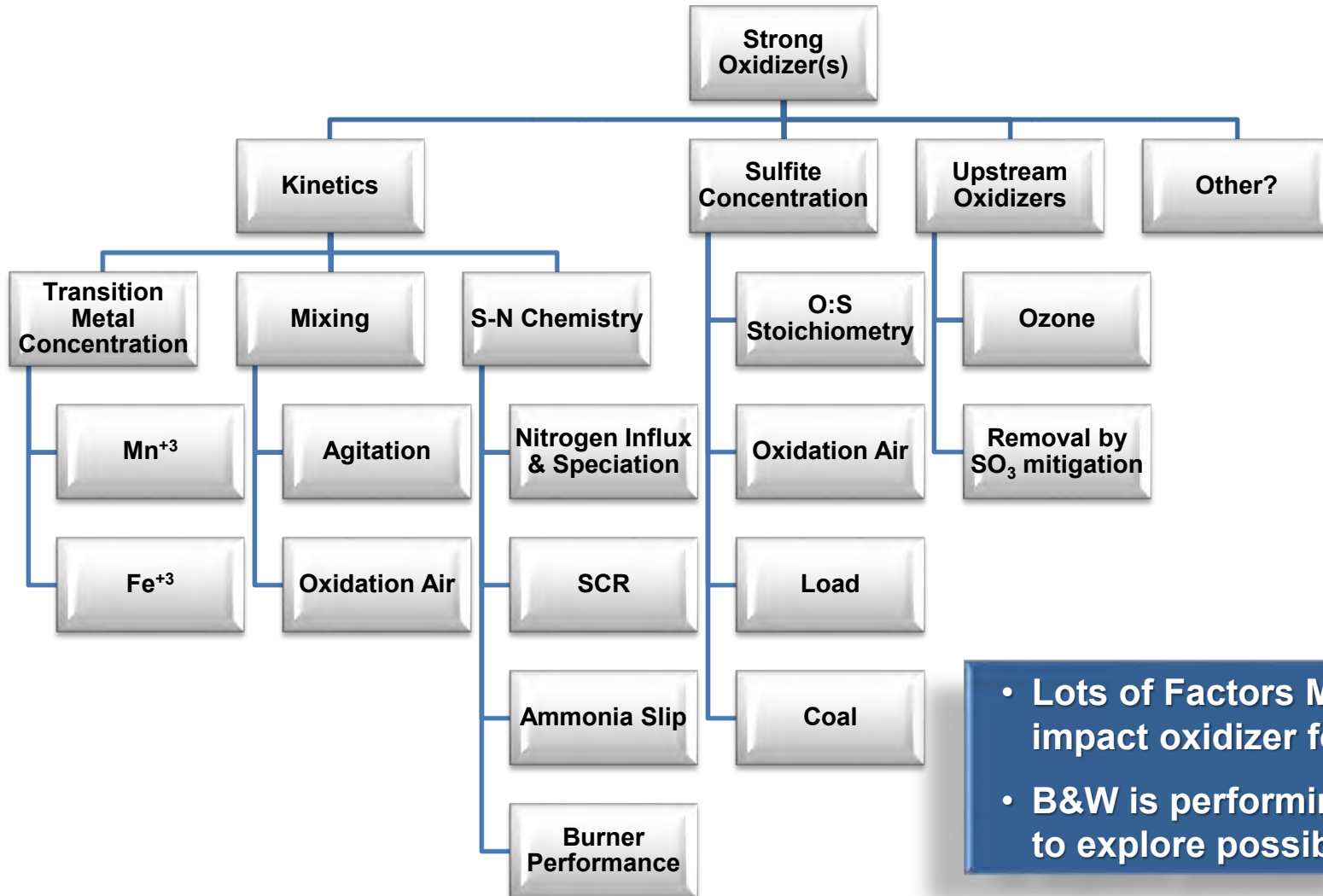

- Lots of Factors MAY impact oxidizer formation
- B&W is performing testing to explore possible causes

Impacts of ORP on WFGD Blowdown

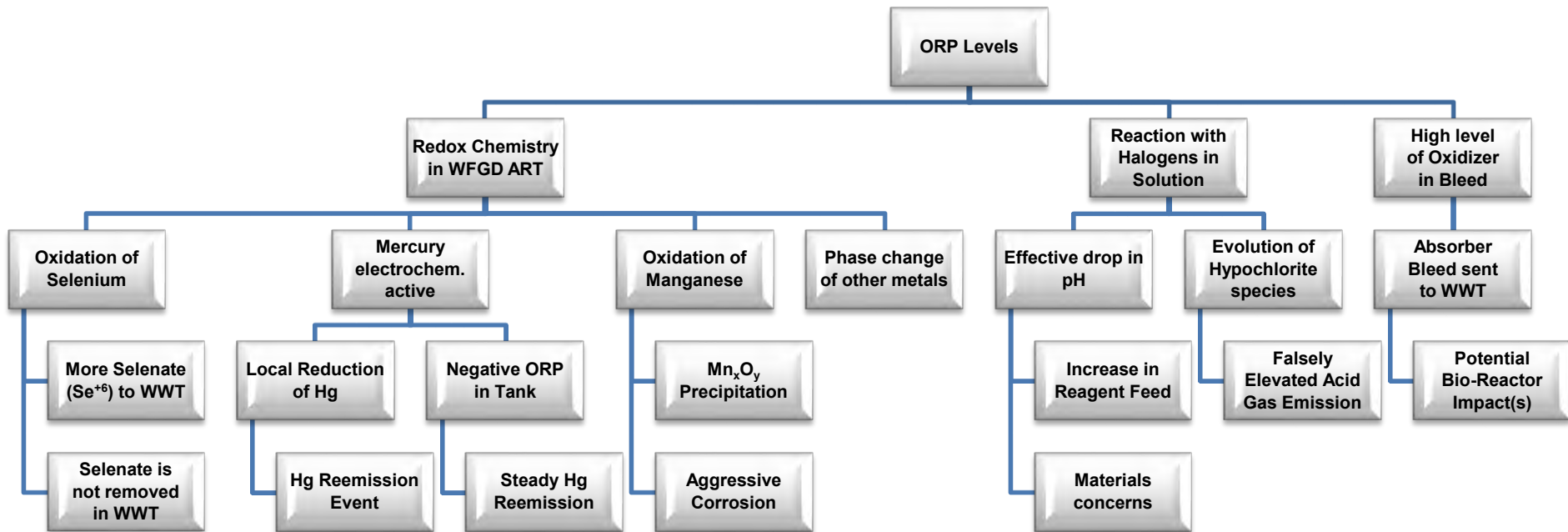

The System View

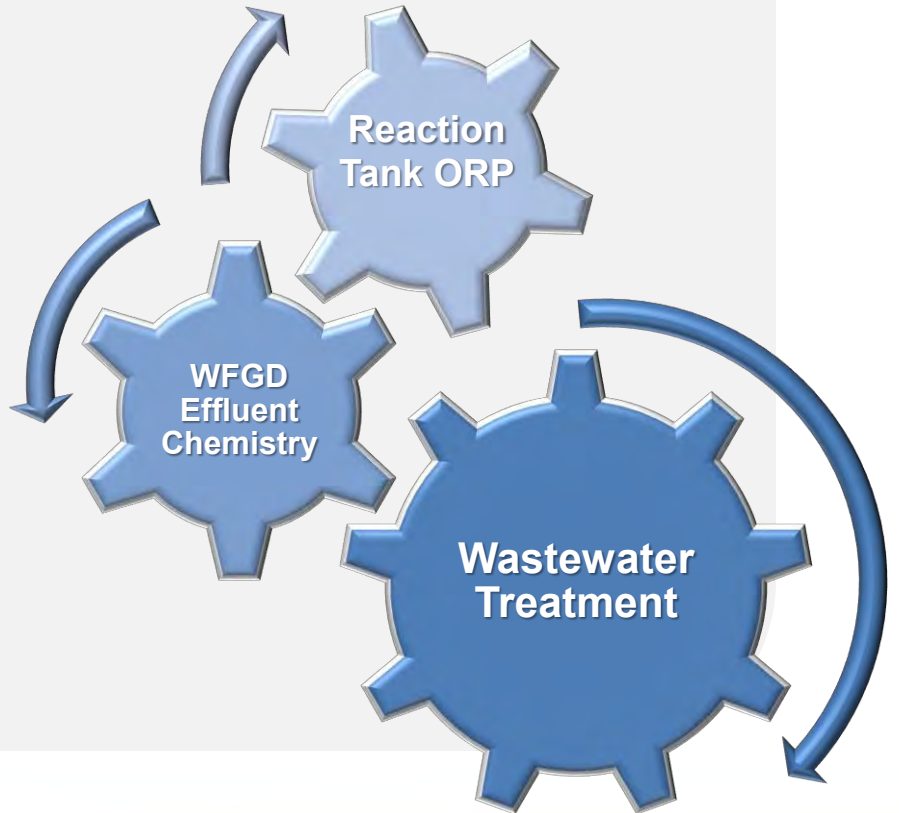
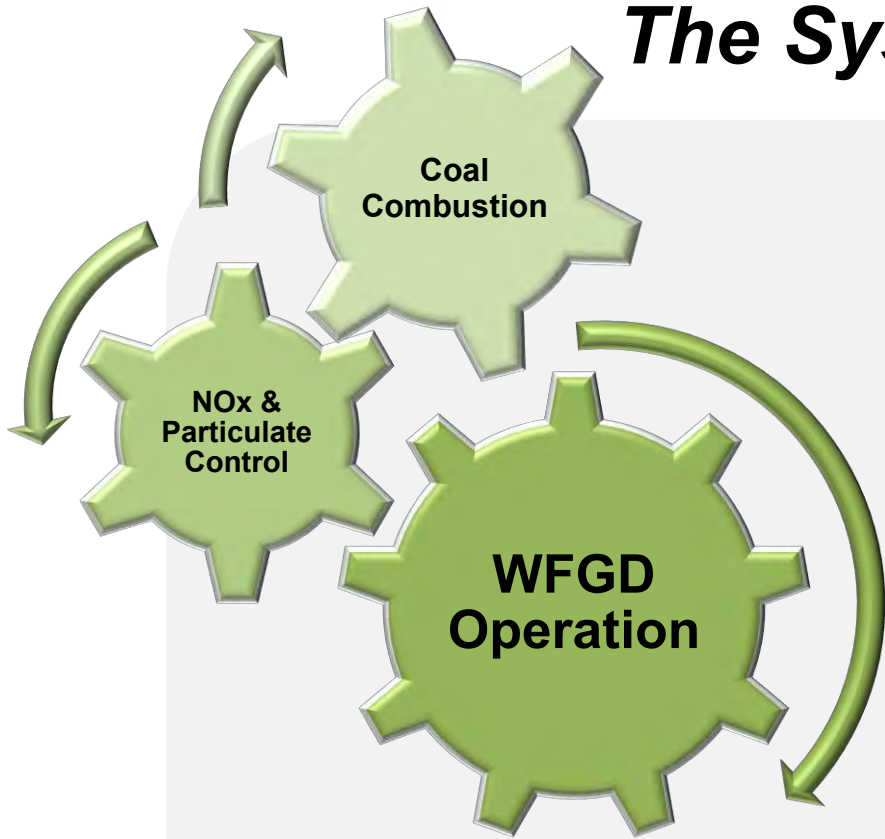

A close-up photograph of a water droplet falling into a pool of water, creating a series of concentric ripples. The water is a vibrant blue color, and the lighting highlights the droplet's surface and the ripples.

System Implications and Tuning

Why Tuning/Controls?

- ✓ **Tuning of AQCS chain for tailored bleed stream composition and loading eliminates or decreases the need for costly additives**
- ✓ **Decreased operating cost**
- ✓ **Improved response to load swings**
- ✓ **Improves wastewater treatment unit operation performance, ensuring compliance**



Effluent Optimization

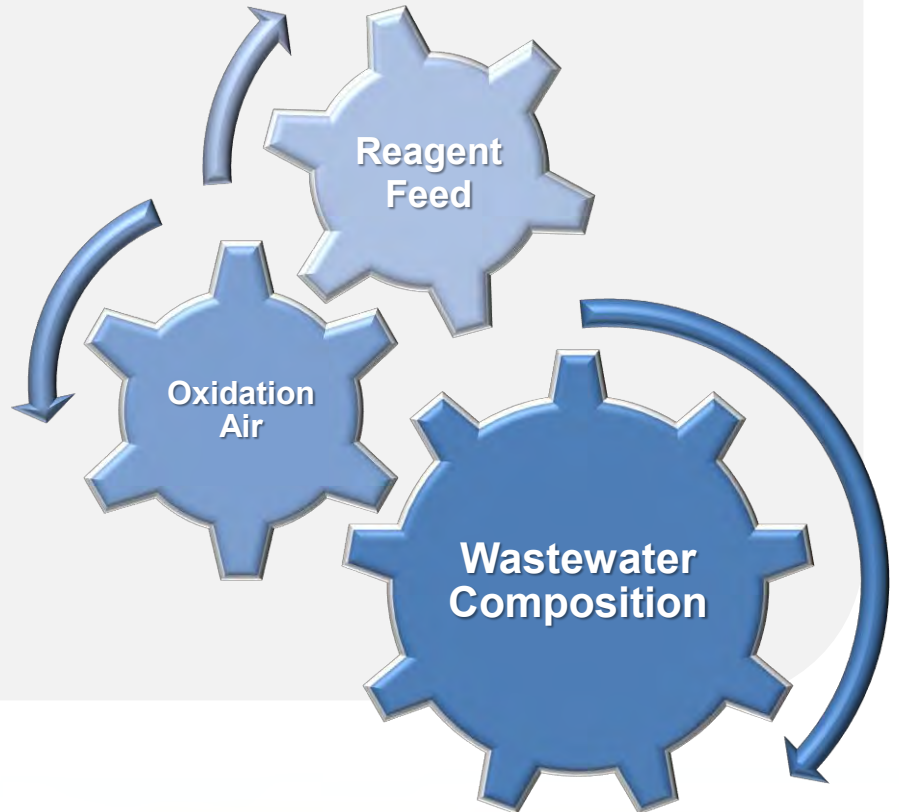
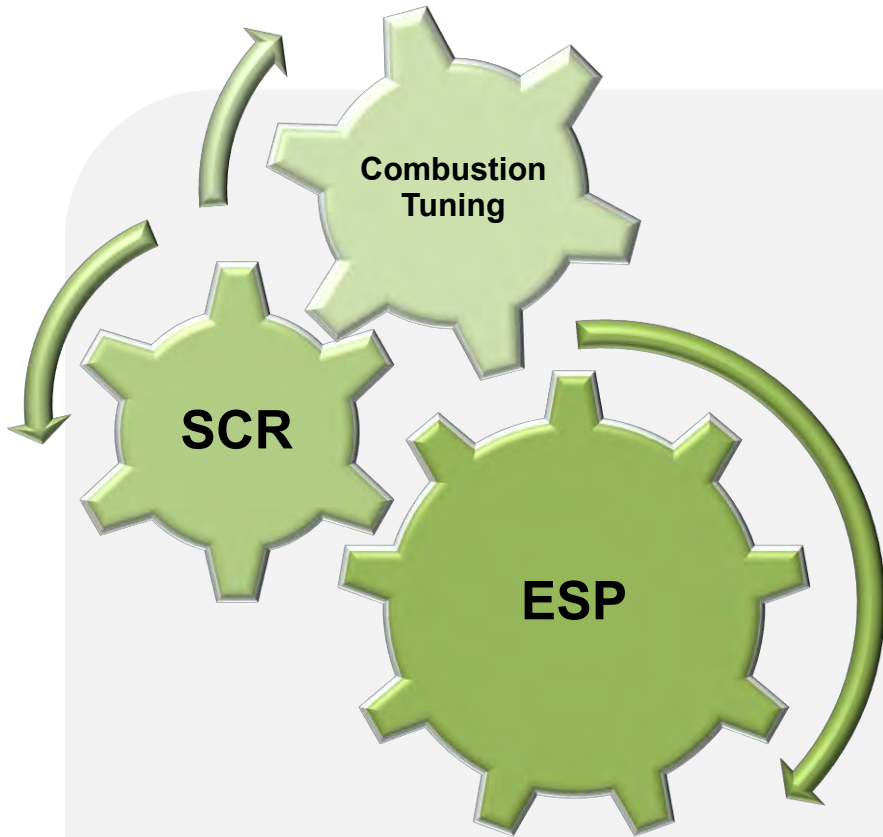

WFGD System Control

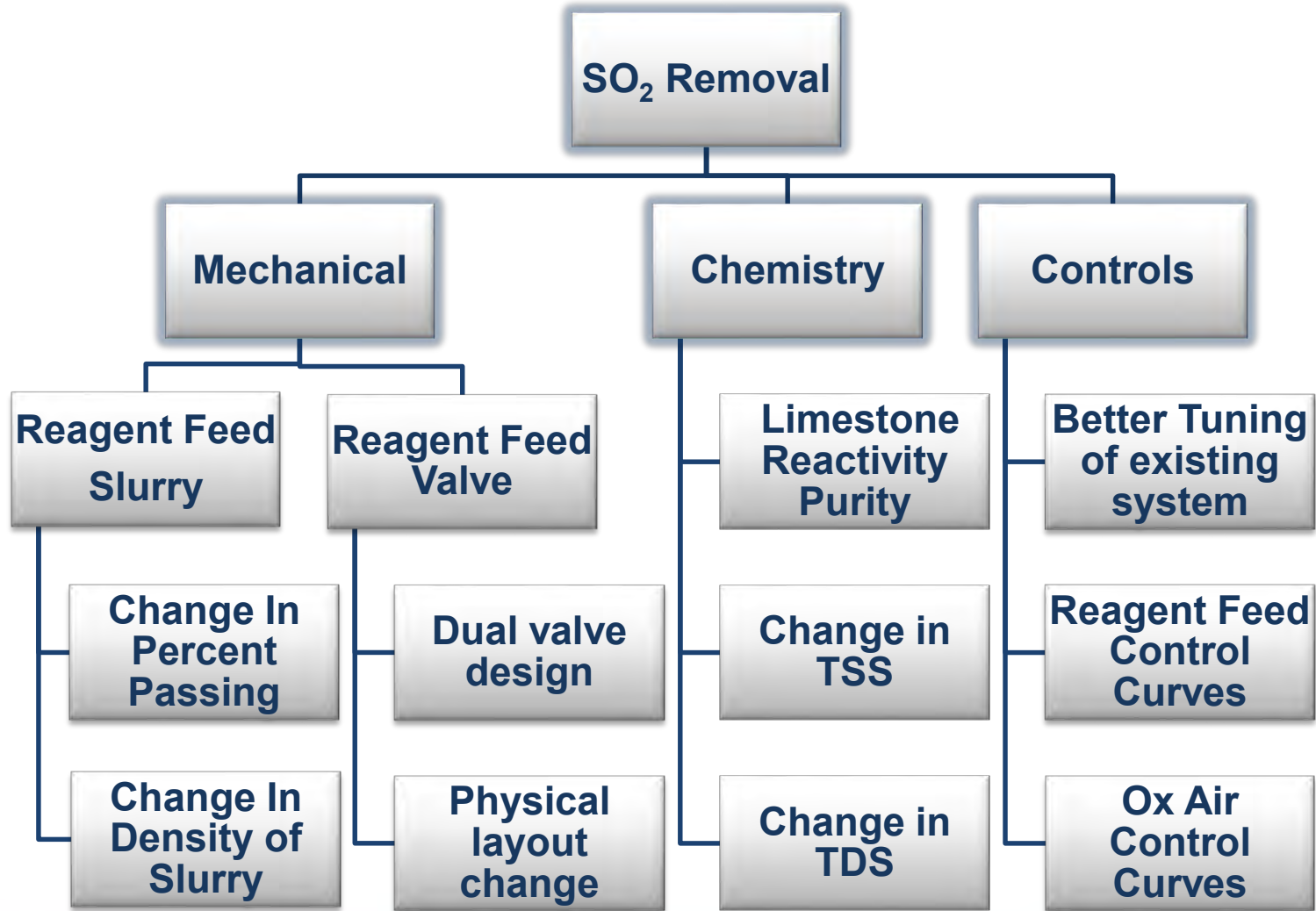

SO_2 to $CaSO_4$ Conversion

Basic Equations

Basics of conversion

- The conversion from $SO_2(g)$ to $CaSO_3^- (aq)$ occurs in the spray zone of the tower
- The conversion causes the slurry to become acidic, which is the cause for the drop in pH
- The acidic slurry causes the limestone slurry, $CaCO_3$, to disassociate. This allows for the formation of the calcium sulfite, $CaSO_3$
- Oxidation to $CaSO_4$ in ART

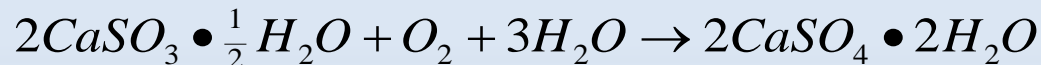
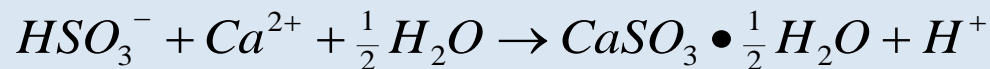
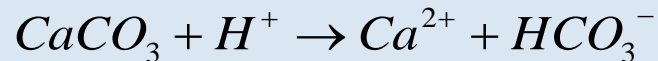
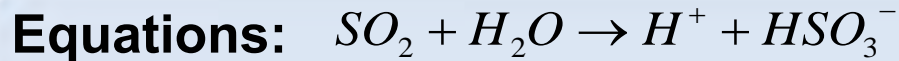

SO₂ to CaSO₄ Conversion Higher ORP Levels

Effects of Higher ORP Levels

- Strong Oxidizers react with halogen species in the slurry
- Higher ORP levels may have an effect higher gypsum purity
- Associated drop in pH from interaction

Equations:

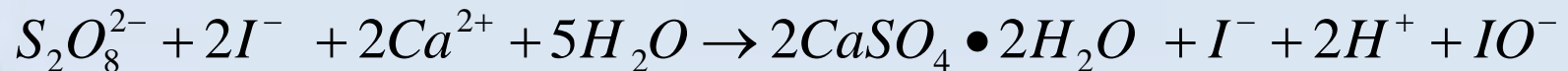
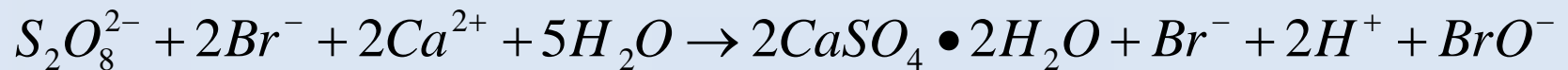
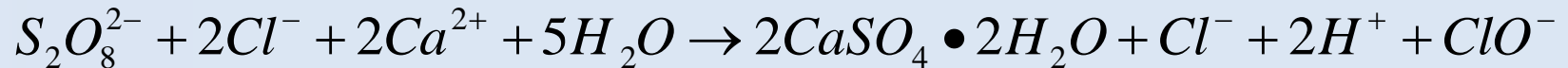

Oxidation Air System



Oxidation Air

Example Oxidation Air Flow Control Curve

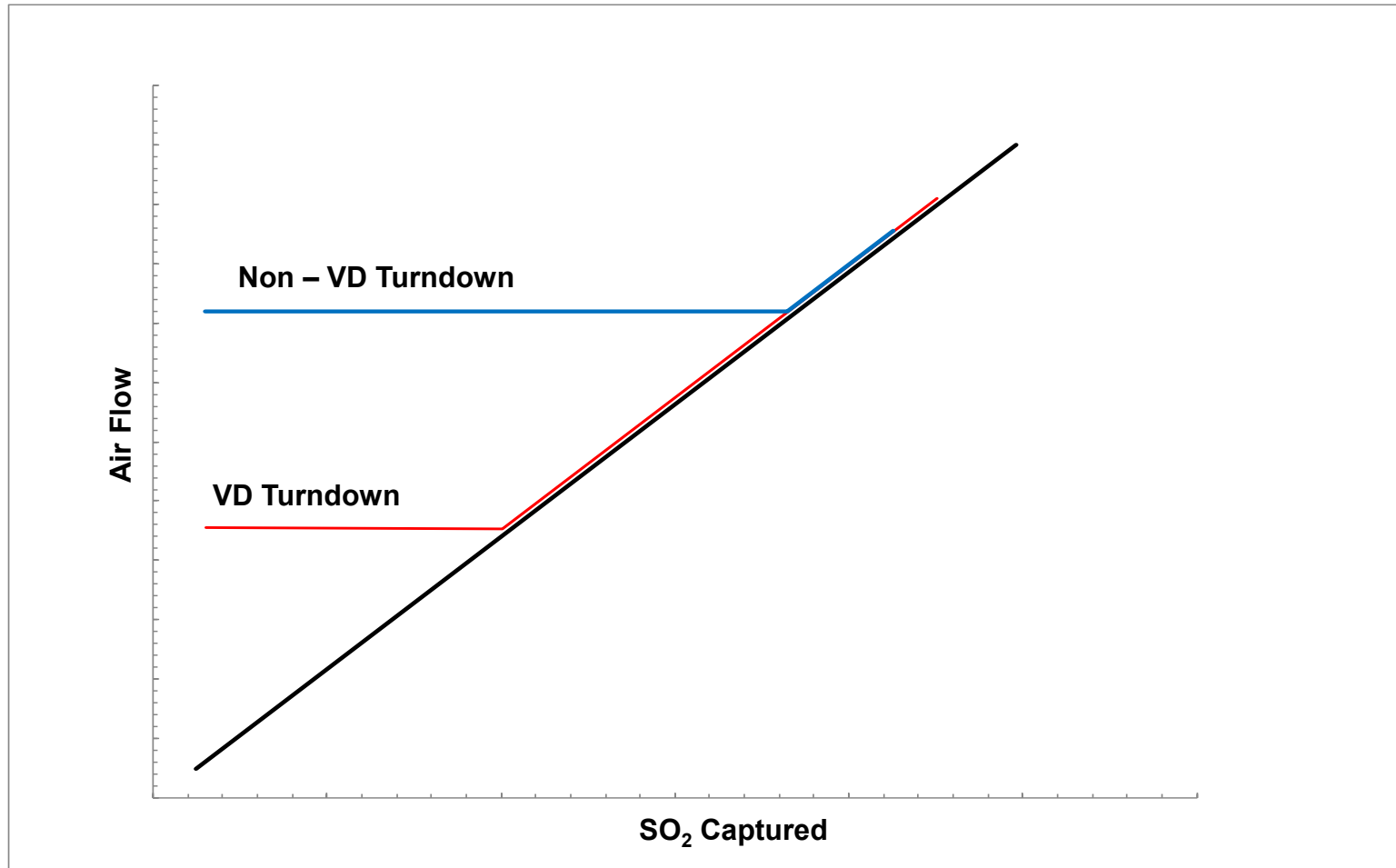

Oxidation Air

Calculated Air Flow

- **Stoichiometry ratios based upon a contract specification**
- **Sized for full load based upon design sulfur coal and full load boiler operation**
 - **Some compressors have an integrated variable diffuser vane allowing for a lower turndown of 45% of full load capacity**
- **During low sulfur coal operations oxidation air required is decreased**

ORP Control using Oxidation Air

- **B&W is working on developing curves for Oxidation Air Flow vs absorber tower load**
- **ORP control can be regulated by having excess sulfites in the system**
- **The turn-down of the compressor can be a trim function for high ORP conditions**
- **Currently no online measurements for sulfites in liquid phase**
 - **B&W working on developing correlations based on ORP**

Bleed System

Function

- **Control Total Suspended Solids, TSS**
 - **Gypsum Production**
- **Control Chloride Concentration in the absorber tower, TDS**
 - **Secondary Dewatering System Overflow**

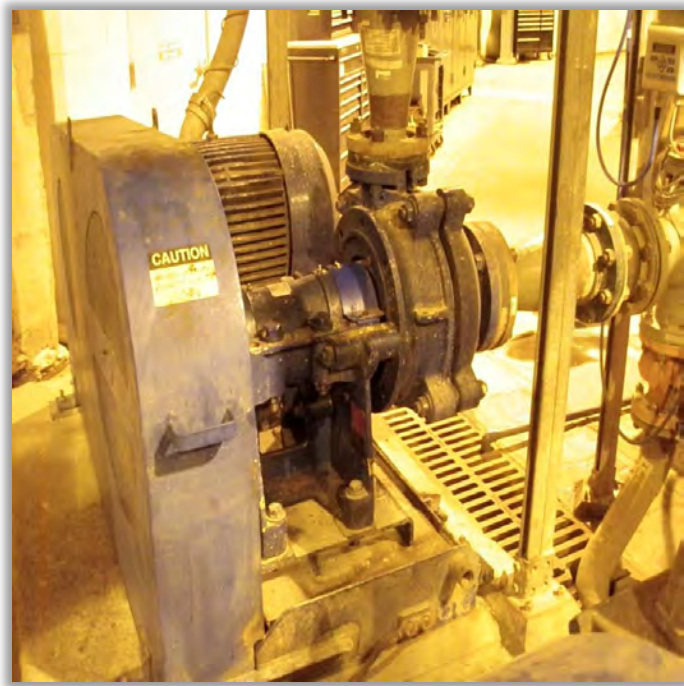

Bleed System

Adjustment of TSS

- **A higher TSS has been shown to help increase removal of SO₂**
 - **Sluggish Controls**
 - **Pump Vibration increase**
 - **Decrease the blow down rates**
- **Variation of TSS may be one control parameter for gypsum crystal growth**
- **In sites without Secondary Dewatering, TSS adjustment will regulate TDS**

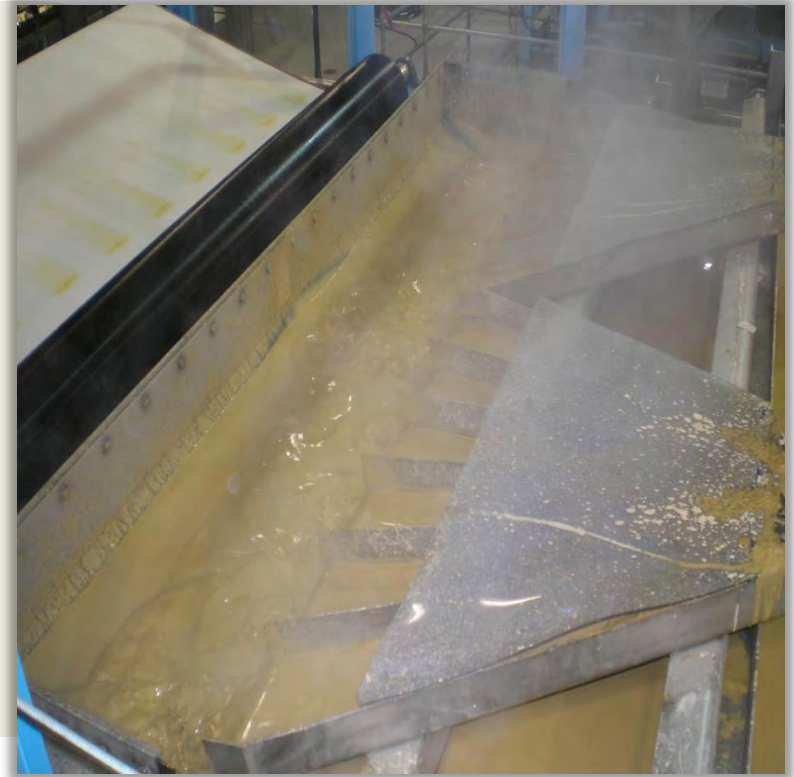

Chloride Purge Stream

Control of Chloride Level

- Function of secondary dewatering
- Slip-stream
- Allowable levels are function of alloy
- Control of other dissolved solids
 - ORP levels effect phase-partitioning and oxidation state
- Optimization of WWT

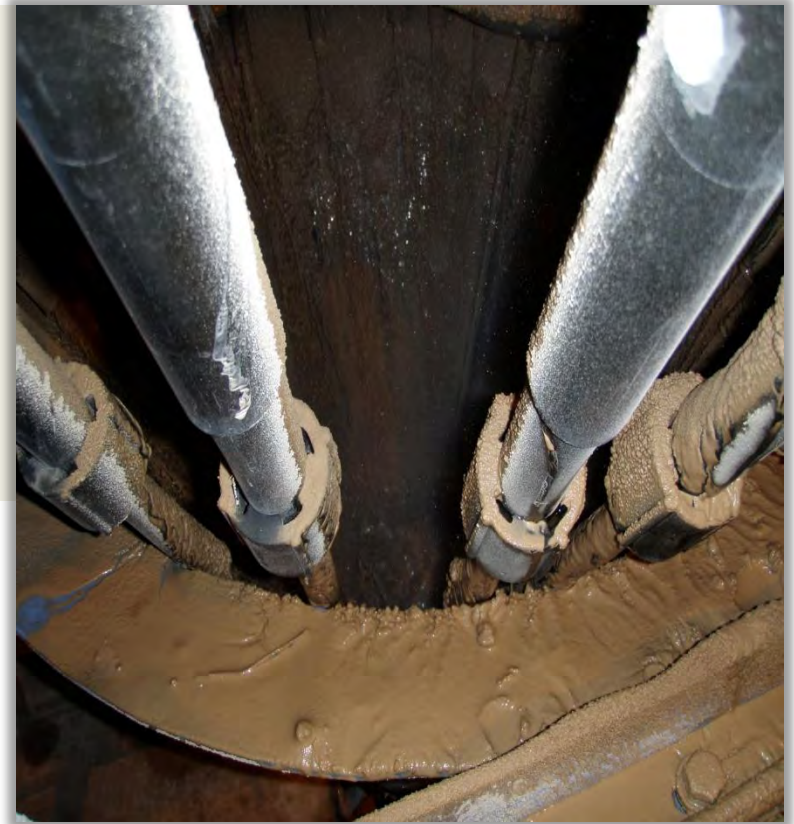

Optimization – Water Balance

Control of TDS going to Waste Water Treatment

Decrease of TDS in Absorber

- Increase blow down rates
- Larger volume/lower concentration
- Increased Make-up Water

Increase of TDS in Absorber

- Decrease blow down rate
- Corrosion Potential increased
- Possible decreased reactivity

Chloride Concentration Increase

- Possible increase in oxidized Hg
- Increased dissolved Hg species

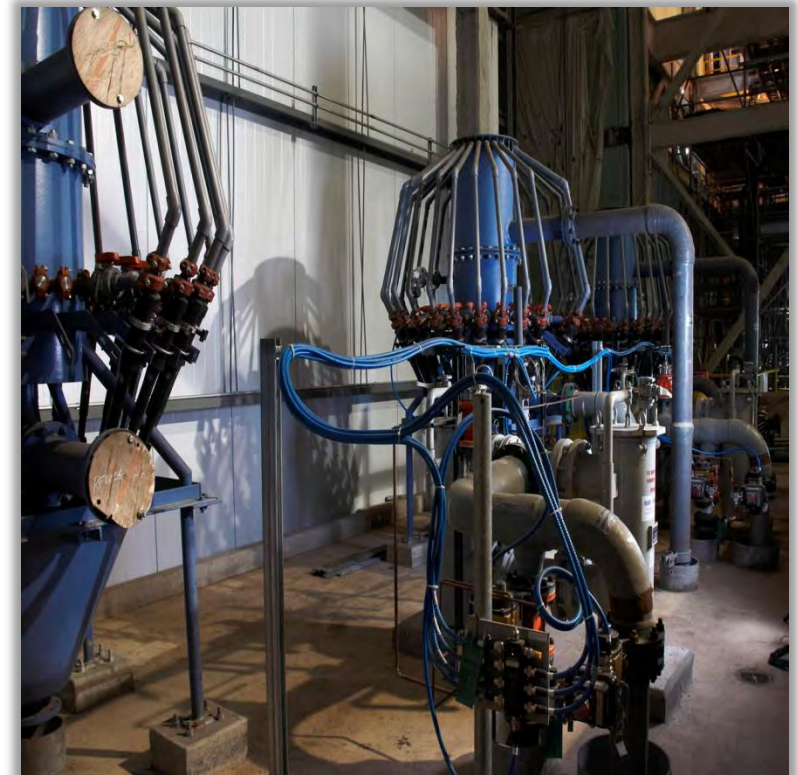

Optimization – Dewatering

Hydroclone Tuning

- **Improved split between gypsum and wastewater**
- **Removal of excess water from gypsum slurry**
- **Improved operation of filter system**

Operational Strategy for tank management

- **Constant flow rates to WWT**
- **Ease of tank level management**
- **Constant dilution water to absorber**

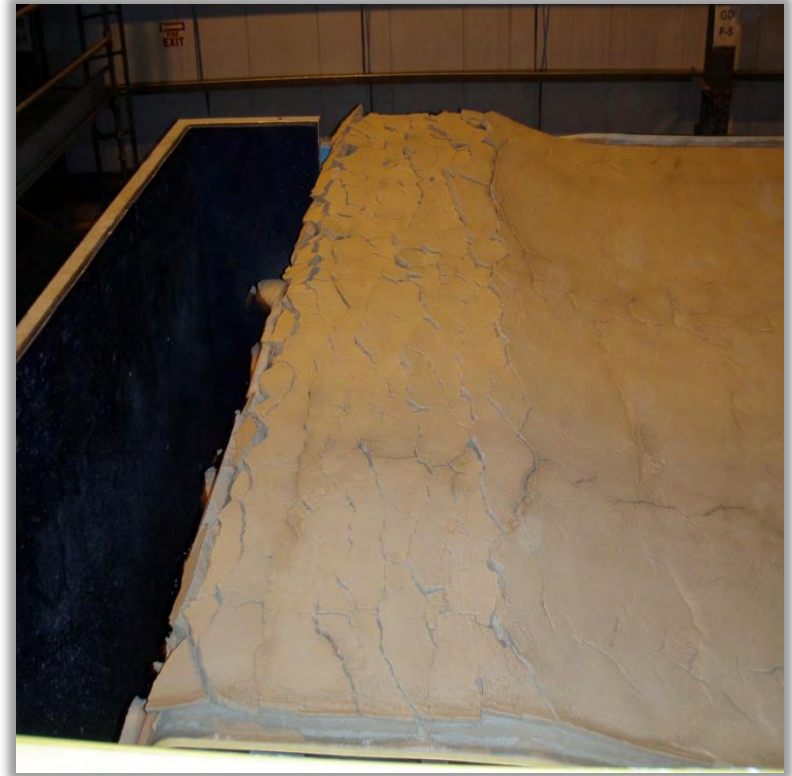

Potential Mitigation Strategies

System Impact

- Integrated control & tuning of AQCS chain

Fine Adjustment

- Optimization of WFGD Chemistry & Control
- Reduced Oxidation Air

Medicine

- Injection of Reducing Agents

?

- Other



pH and Oxidizer Content

High ORP & pH Drop

- **High ORP results from a high concentration of strong oxidizers**
- **Oxidizers will continue to react with stream constituents until equilibrium is reached.**
- **WFGD absorber slurries are NOT at thermodynamic equilibrium at the time of bleed**
- **Strong oxidizers will react with the halogens in solution**
 - **Liberating halogen containing gas**
 - **Releasing hydronium ions in solution**
 - **After buffering solids are removed, pH could decrease downstream**

Strength of Oxidizers

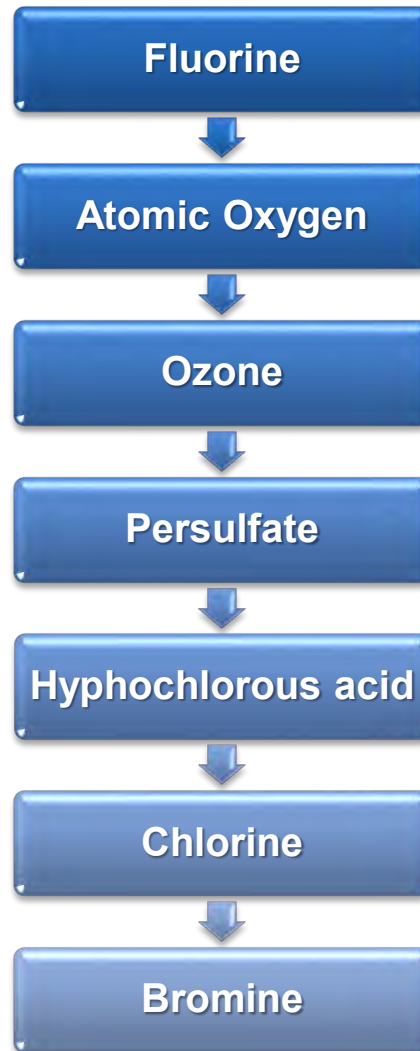

$S_2O_8^{-2}$ and pH Drop

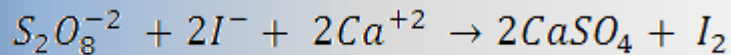
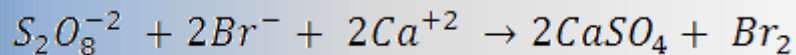
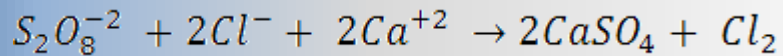

High ORP
levels can
lead to
hypochlorite
formation

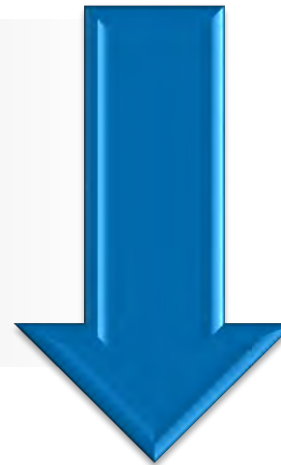
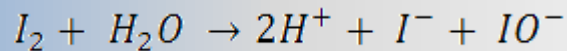
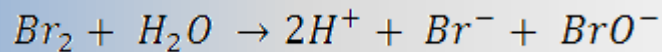
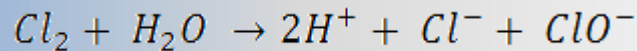

pH Drops
from Acid
Formation

Impact Downstream

Bioreactor and oxidizer

- **Strong oxidizer in the effluent stream**
- **Microbes can be killed**

pH drop with high ORP

- **Buffer capability of slurry removed from dewatering**
- **Low pH may be fed to Wastewater Treatment**





Selenium

Selenium Chemistry

Selenite

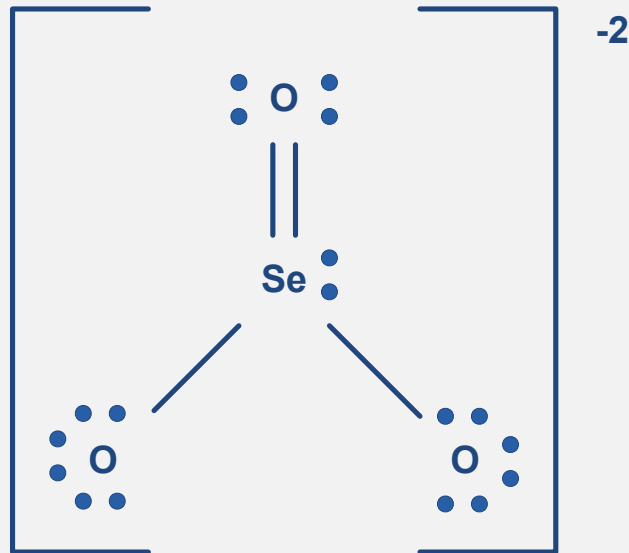

- HgCl , Hg_2Cl_2
- Mercury in +1 oxidation state
- Less Stable

Selenate

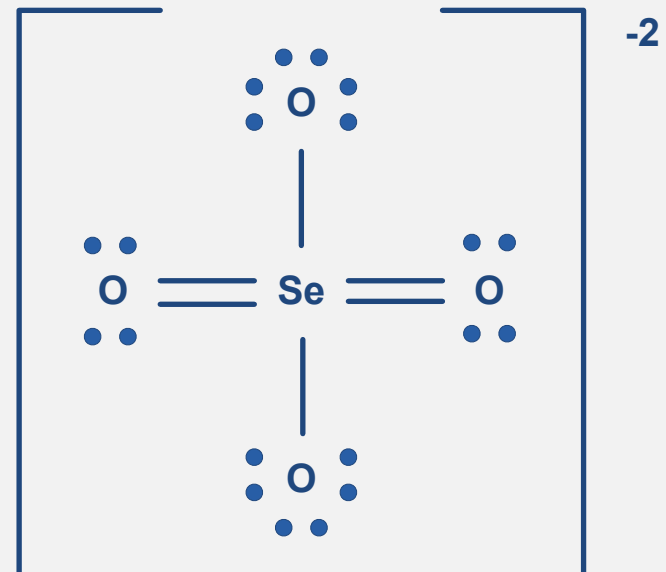

- Selenium in +6 oxidation state
- $\text{Se}^0 \rightarrow \text{Se}^{+6} + 6e^-$

Selenium

In a ORP environment < 300 mV

- **Selenite, Se^{+4} will be the dominate form**
- **Selenium removal is optimal for waste water treatment**
- **Solid phase**

In a ORP environment > 300 mV

- **Selenate, Se^{+6} will be dominate form**
- **Selenium will pass through wet-lands**
- **Dissolved phase**
- **Difficult to remove by chemical precipitation**

Phase Partitioning– Selenium

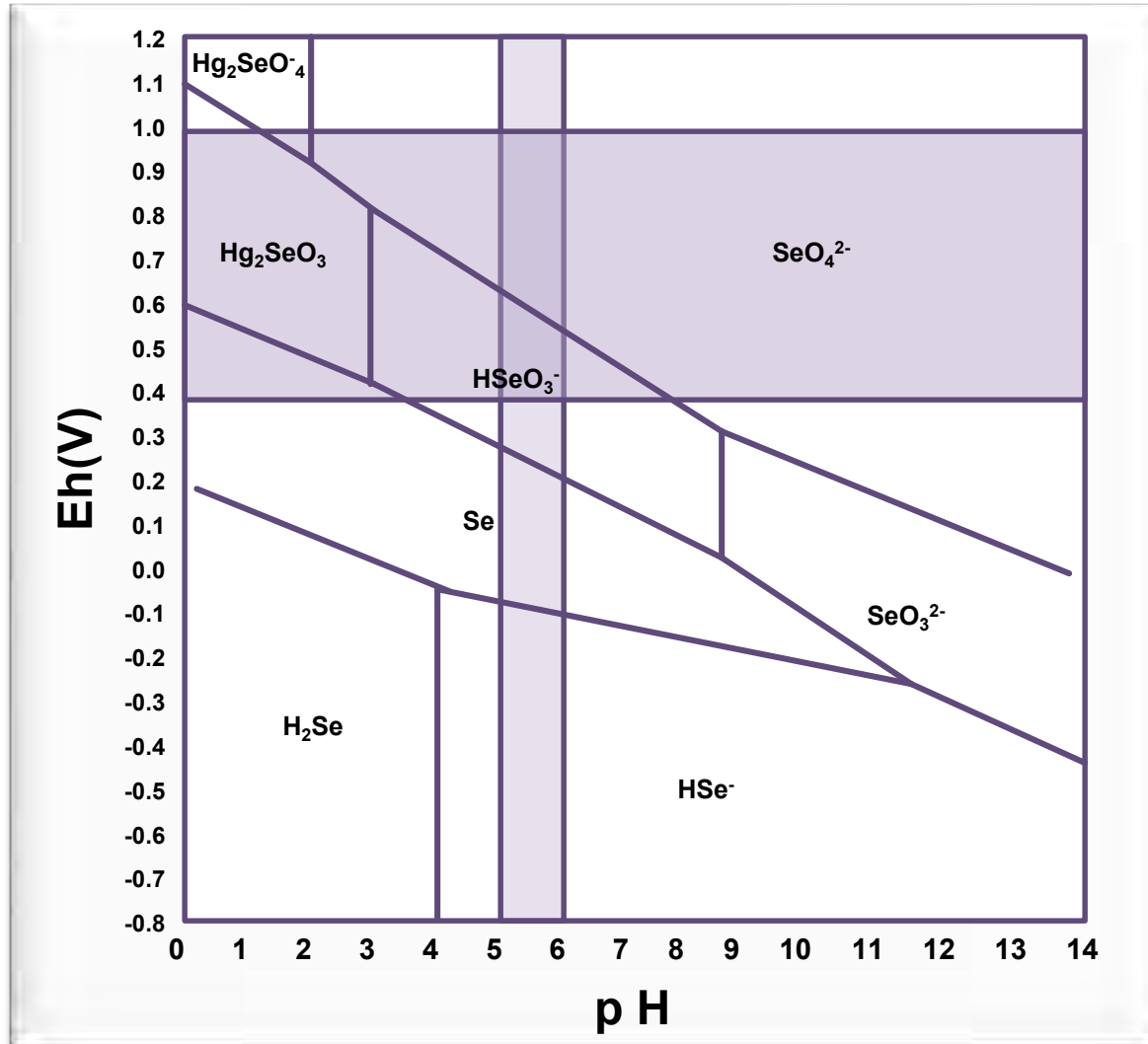

Selenite vs. ORP in WFGD ART Slurry

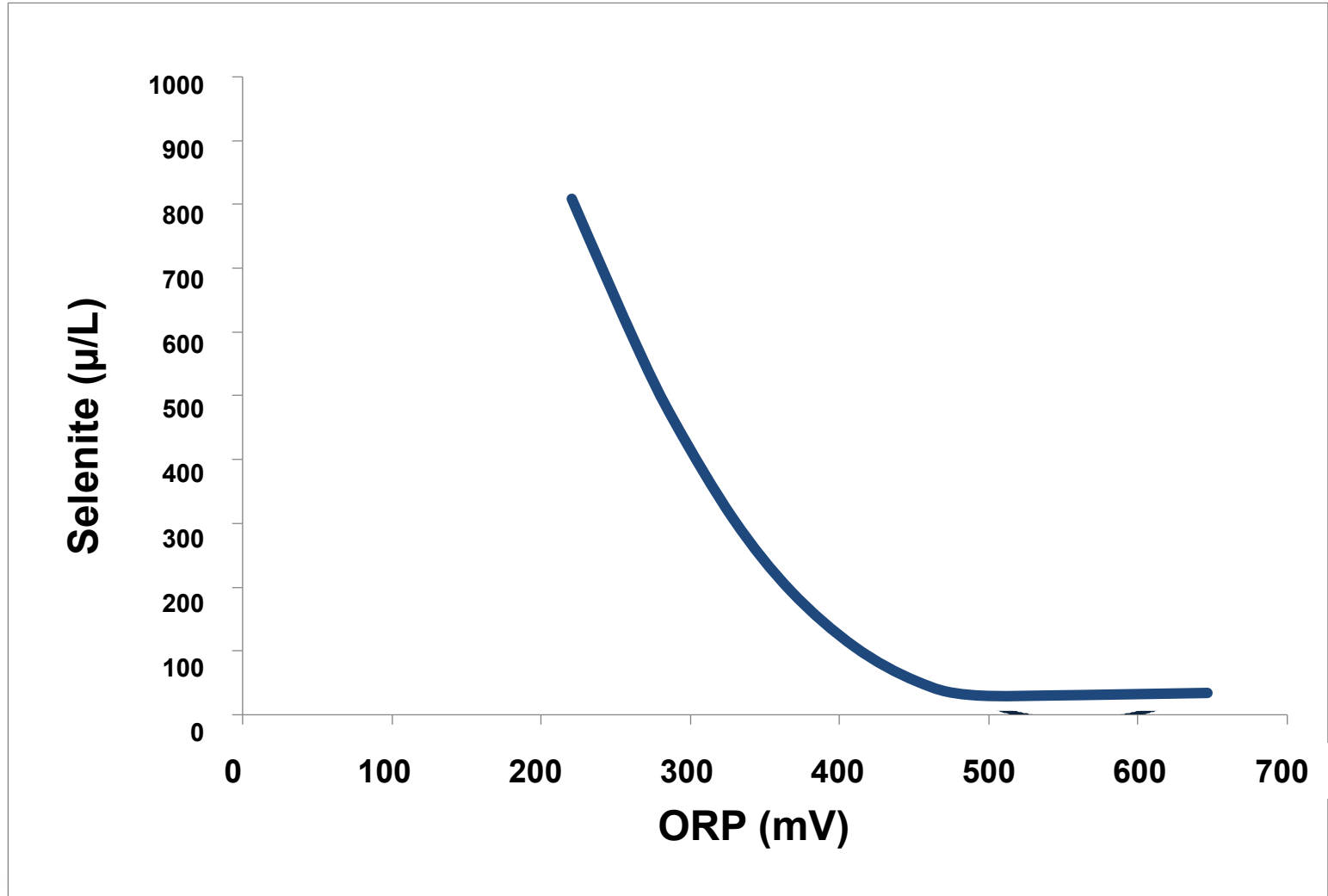

Selenate vs. ORP in WFGD ART Slurry

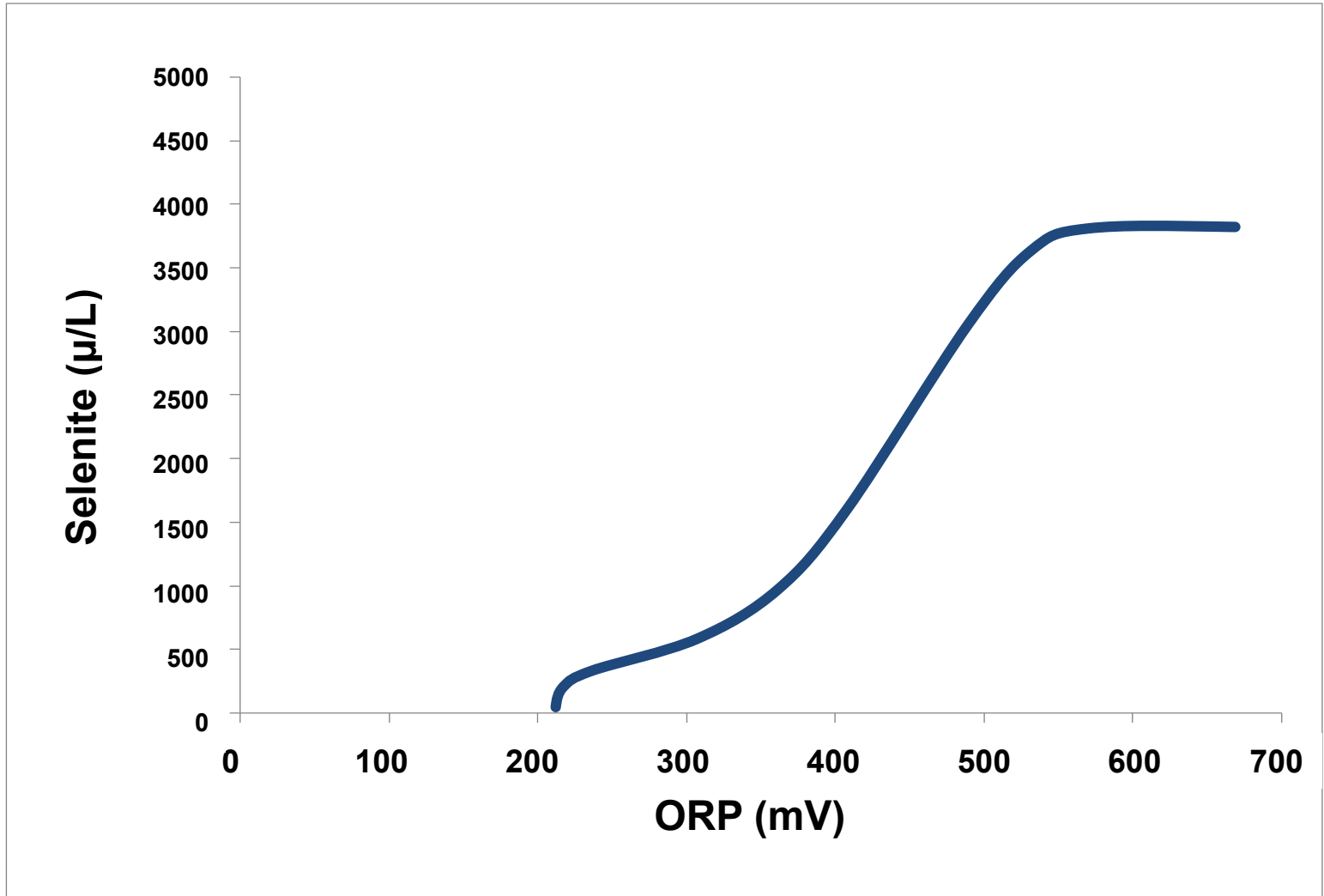



Mercury

Speciation of Hg During Coal Combustion

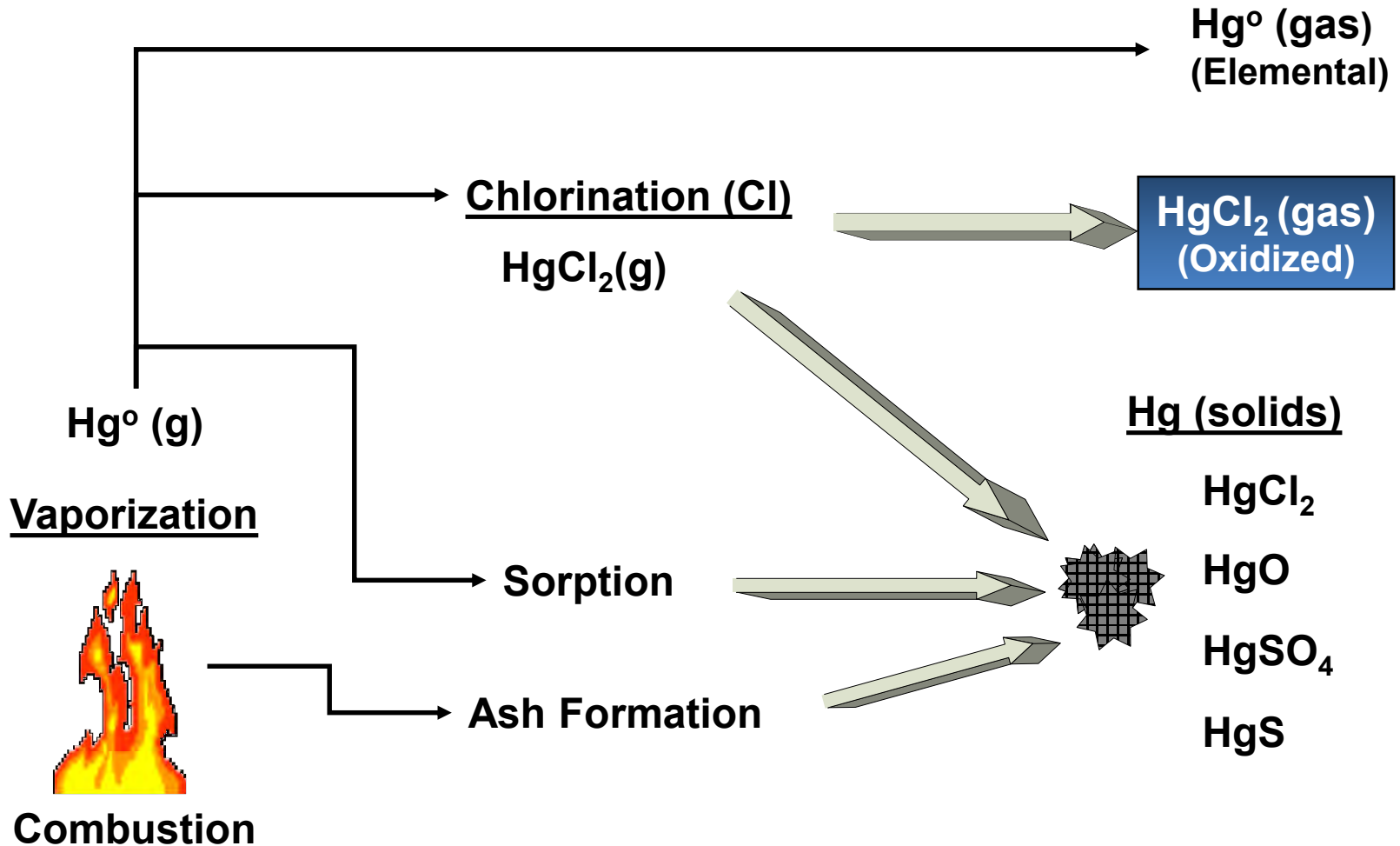

Mercury Speciation by Fuel Type

Flue Gas Speciation

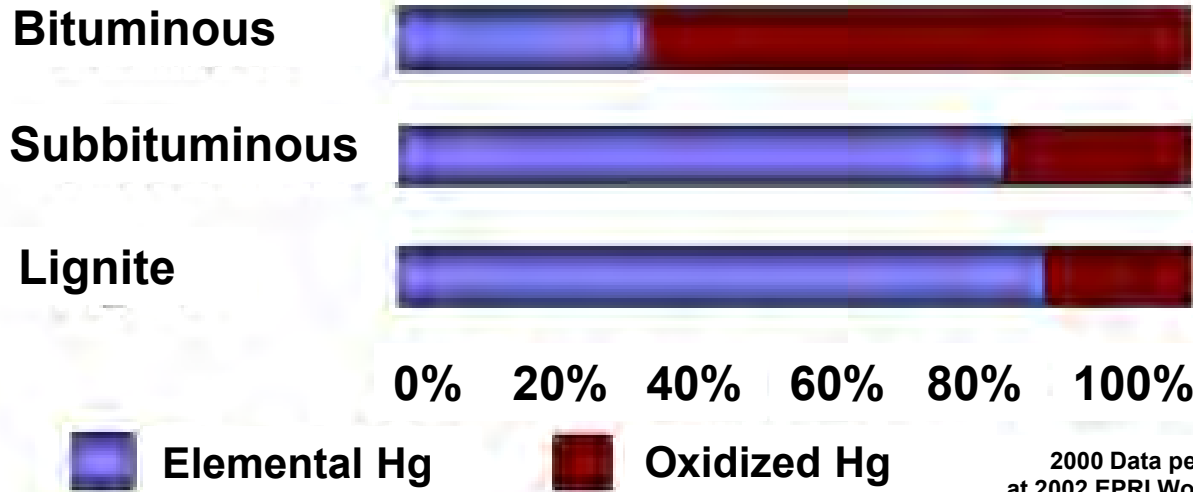

2000 Data per NETL
at 2002 EPRI Workshop

Influences on Hg Speciation



Gas Composition
(i.e., Chloride)



Unburned Carbon (UBC)



Catalysts
(i.e., SCR, Ash, Boiler Metals)

Mercury

Within the bleed stream Mercury state is:

- **Particle Bound**
- **Dissolved Ionic Salt**
- **Precipitated**

ORP levels ~500 mV dissolve $\text{Hg}^{2+,4+}$ increases

Emission of dissolved Mercury from the tanks

- **Stagnate water may lead to stratification of ORP levels**
- **Mixing of stratified layers may change bulk ORP**
- **Keep circulation of fluid in tanks**

Chloride Levels in the Slurry

- **May aid in the oxidation of the Mercury**



Mercury Chemistry

First Ionization



- HgCl, Hg₂Cl₂
- Mercury in +1 oxidation state
- Less Stable

Second Ionization

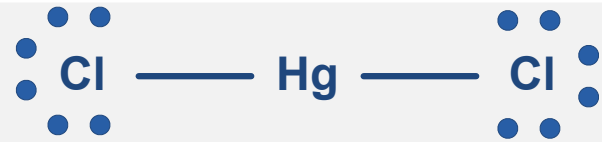

- HgCl₂
- Mercury in +2 oxidation state
- More Stable

Mercury Re-emission in WFGD

Overall Reactions:

- 1. $\text{HgCl}_2 + \text{HSO}_3^- + \text{H}_2\text{O} \rightarrow \text{Hg}^0 \uparrow + \text{SO}_4^{2-} + 3\text{H}^+ + 2\text{Cl}^-$**
- 2. $2\text{Me}^{2+} + \text{Hg}^{2+} \rightarrow \text{Hg}^0 \uparrow + 2\text{Me}^{3+}$**

Mercury Re-emission

- **ORP effects mercury emission in WFGD absorbers**
- **Strongly reducing conditions within the scrubber will cause Hg^{+2} to be reduced to Hg^0 and re-emitted**
- **Mercury is a very electrochemically active species**
- **Transitions in ORP have been implicated in Hg re-emission events**



Phase Partitioning– Mercury

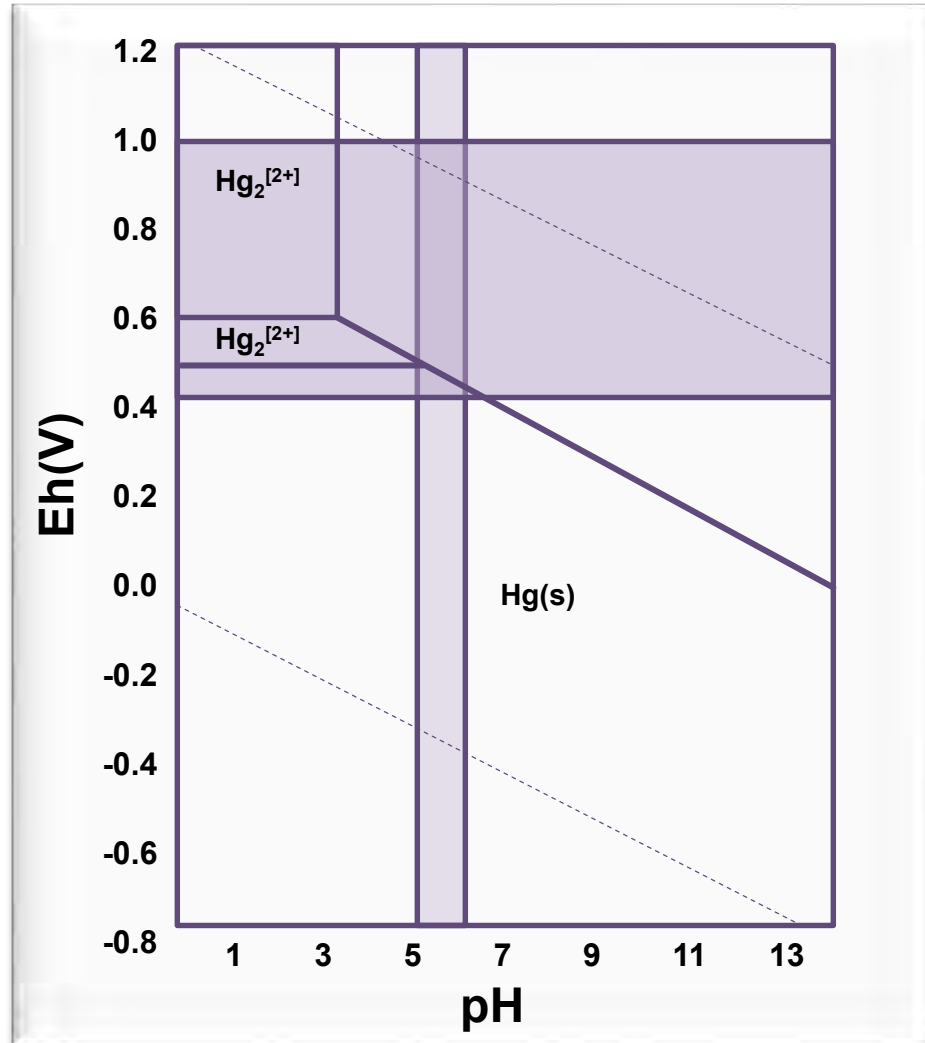

Dissolved Mercury vs. ORP in WFGD ART Slurry

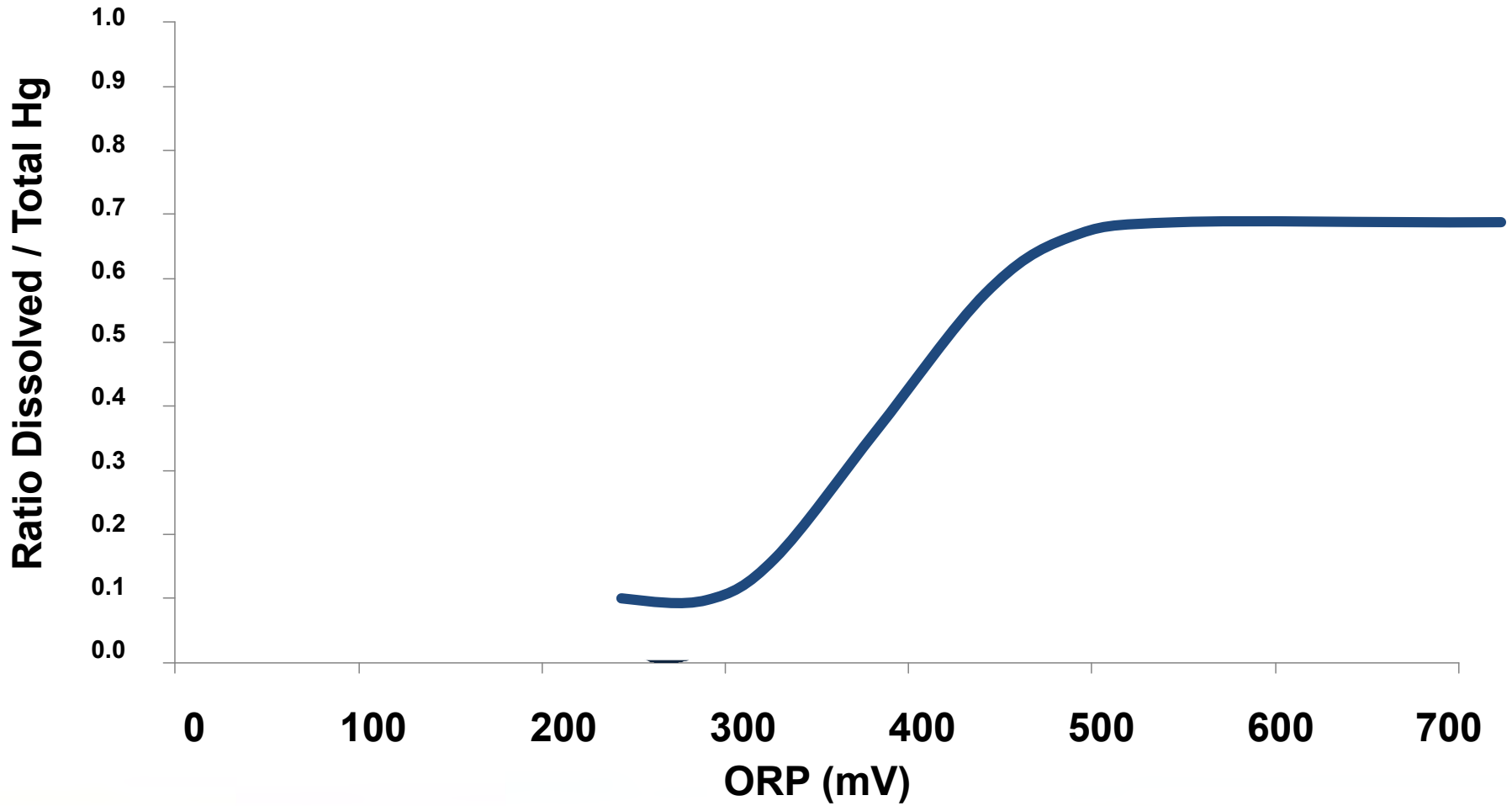

A close-up photograph of a water droplet hitting a surface, creating a series of concentric ripples. The water is a vibrant blue color, and the lighting highlights the droplet's shape and the texture of the ripples.

Conclusions

Conclusions

- ✓ Absorber System can be controlled for better results on variation of loads
- ✓ WFGD Bleed Streams can be tuned for optimal bleed stream composition and flow rate. The WFGD Bleed stream composition is important to performance of wastewater treatment operations.
- ✓ By tuning the Bleed Stream, performance of WWT unit operations is consistent or enhanced
 - ✓ Oxidation state and phase partitioning of metals (Se, Hg, etc...)
 - ✓ pH, ORP, Dissolved halogen content (F-, Cl-, Br-, I-)
- ✓ Optimization can accomplished by:
 - ✓ Integrated control of the AQCS chain
 - ✓ Integrated control of combustion systems
 - ✓ Optimizing the WFGD (tuning)
 - ✓ Chemical Additives
- ✓ Industry thought process change



Questions

